

NOTES :

MATERIAL: SIEHE JEWEILIGE EINZELTEILE/SEE EACH PIECE OF PART
 WEIGHT: ASSEMBLY (STEEL SECTION ONLY): 167448 Kg
 TOP SECTION: 45092 Kg
 MID SECTION A: 54338 Kg
 MID SECTION B: 68018 Kg

1. DIE AUSFUHRUNG DER OBEREN SEKTION ENTSPRECHEND DER Z.-Nr.: 446W5574
 DESIGN OF TOP SECTION ACC. TO DWG.-NO. 446W5574
2. DIE AUSFUHRUNG DER MITTLEREN SEKTION A ENTSPRECHEND DER Z.-Nr.: 446W5575
 DESIGN OF MID. SECTION A ACC. TO DWG.-NO.446W5575
3. DIE AUSFUHRUNG DER MITTLEREN SEKTION B ENTSPRECHEND DER Z.-Nr.: 446W6420
 DESIGN OF MID. SECTION B ACC. TO DWG.-NO.446W6420
4. DIE AUSFUHRUNG DER BETONSEKTIONEN, DES ADAPTERS UND DER ANKERBOLZEN ENTSPRECHEND SEPARATER HERSTELLERZEICHNUNG.
 DESIGN OF CONCRETE SECTIONS, ADAPTER AND ANCHOR BOLTS ACC. TO SEPARATE SUPPLIER DRAWING.

FLANSCHBOLZENGARNITUREN:
 - GROESSEN <M36 GEMAESS EN14399-4 - HV - 10.9/10 - TZN
 - GROESSEN >M39 GEMAESS DAST-R1 021 10.9 - TZN (DAST-RICHTLINIE 021, SEPT. 2013)
 - JEDE GARNITUR BESTEHEND AUS 1X SCHRAUBE, 1X MUTTER, 2X SCHEIBE, GESCHMIERT MIT MOS2

- FLANGE BOLT SETS:
 - SIZES <M36 ACC. TO EN14399-4 - HV - 10.9/10 - TZN
 - SIZES >M39 ACC. DAST-R1 021 10.9 - TZN (DAST-RICHTLINIE 021, SEPT. 2013)
 - EACH BOLT SET CONSISTING OUT OF 1X BOLT, 1X NUT, 2X WASHER, LUBRICATED WITH MOS2
5. MF2 MONTAGEFLANSCH GESCHRAUBT / FLANGE BOLT:
 130X M36X235; KOMBINIERTES ANZUGSVERFAHREN, M = 1920Nm + 90° WEITERDREHWINKEL
 130X M36X235; COMBINED METHOD, M = 1920Nm + 90° NUT ROTATION
 6. MF3 MONTAGEFLANSCH GESCHRAUBT / FLANGE BOLT:
 121X M48X250; KOMBINIERTES ANZUGSVERFAHREN, M = 4450Nm + 90° WEITERDREHWINKEL
 121X M48X250; COMBINED METHOD, M = 4450Nm + 90° NUT ROTATION

7. DICHTUNGSMATERIAL
 SEALING COMPOUND
8. VERSCHLUSSKAPPEN
 PLUGS

REVISION HISTORY			
REVZONE	DESCRIPTION	DATE (YYYY-MM-DD)	APPROVED
-	THIS DRAWING WAS CREATED PER ECR3041224		

REVISE ON CAD ONLY
 NX PART: 446W7589

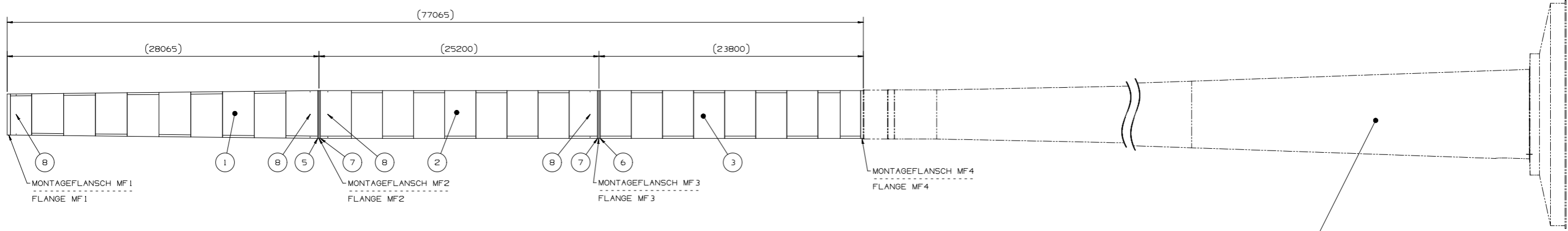

4.X 161mHH HYBRID TOWER

Anlage Nr.: 1
 zum Bericht: T-7009/18-1 Rev. 0
 vom: 29. März 2018



© COPYRIGHT 2018 General Electric Company(USA).
 All rights reserved. The information herein is Proprietary and Technically Exclusive content that is solely owned by General Electric Company and/or its affiliates. Thus, it is being provided with the explicit expectation of restricted and privileged use. All persons, or legal entities receiving this information shall be deemed by the act of its receipt to have contractually agreed to make no duplications, reproductions of any nature by any means, modifications, disclosures, or use any portion of this material except as is expressly authorized in writing by General Electric Company and/or its legitimate affiliates.

SEE SEPARATE PARTS LIST		GE CLASS II (INTERNAL NON-CRITICAL)			
UNLESS OTHERWISE SPECIFIED DIMENSIONS ARE IN MILLIMETERS	DWG TYPE ASSEMBLY	GE RENEWABLE ENERGY			
TOLERANCE CLASS: N/A	DRAWN 212300191 DRAWN DATE 1999-MM-DD 2018-02-09 CHECK SEE PLM				
FIRST ANGLE PROJECTION	CHECK DATE 1999-MM-DD	STAHLSEKTIONEN FÜR HYBRIDTURM STEEL SECTIONS FOR HYBRID TOWER ZUSAMMENBAUZEICHNUNG TOWER STRUCTURE ASSY SHELL			
	ENGRD 105051069 ENGRD DATE 1999-MM-DD				
	ADDITIONAL APPROVALS SEE PLM FOR APPROVAL INFORMATION	SIZE	CAGE CODE	DWG NO	
	MATERIAL: N/A	ML/PLM CODE/UNIT TYPE: N/A	AO	NONE	446W7589
	DWG SOURCE: N/A	SCALE	NONE	APPROXIMATE WEIGHT IN NOTES	SHEET 1 OF 1
	SIMILAR TO: 446W4955				
	DWG CODE: US-90, GREENVILLE				

THIS DRAWING IS PREPARED IN ACCORDANCE WITH ISO 1101-2004

UNIFORM SCALE 0:200:1

446W7589

A